

TRUCK-MOUNTED CONCRETE PUMP  
S 28



## SCHWING TRUCK-MOUNTED CONCRETE PUMP S 28 X

### THE VERSATILITY-MACHINE FOR THOSE LIMITED SPACES

Thanks to its low unfolding height of just 5.85 m, this all-purpose machine can be deployed not only on normal construction sites but in enclosed structures such as halls and tunnels as well. Its RZ placing boom was designed to meet the criteria for indoor booms: its superiority is impressively evident when concreting in tight quarters.

Together with the pipes aligned along one side of the boom, the RZ folding system provides for ideal slip and threading properties. Additionally, this machine can reach to a depth of 17.40 m and, thanks to the large bank angle and short wheelbase of just 3.60 m, it is no problem to run off-road or over rough jobsites.

The end hose can be released easily at ground level, dropping out of the holder under its own weight. Continuous pouring is possible from maximum reach right back to the front bumper.

The folding system together with the comparatively large articulation of 104° on the A arm and 270° for the C and D joints, respectively, means that the end hose does not have to be pulled through freshly poured surfaces – in contrast to a simple Z- folding system.

Two slewing cylinders on each side of the boom and the XH outriggers – the vertical cylinders being protected inside square tubes, not subject to any buckling forces - make for even greater operational dependability and maximum service life.





The machine is equipped with removable hose boxes, enabling the operator to use it as a fully functional refurbishment pump.

These boxes can be loaded and unloaded using a forklift, a crane or even the pump's own boom so the pump hoses can get to where they're needed even on cramped construction sites.

The S 28 X provides space for approx. 40 m of hose as standard.

The "jumbo version" can handle 18 five-meter DN 65 hose segments.

As standard, the S 28 X is equipped with pump kits with a stroke of 2 m.

In the basic variant with a pump piston diameter of 200 mm, this pump unit can generate a maximum concrete pressure of 108 bar.

And like all SCHWING truck-mounted concrete pumps it is equipped with the Rock Valve – for exceptional suction and pumping performance, high economy, low wear and excellent dependability.

Upon request this pump is also available with an optional compressor, which is radio remote-controlled; if desired, air/water lines can be mounted up to the tip of the boom.



In the working position the extended cylinders are on the top of the boom. This protects them from collision and concrete spills. In the working position the extended cylinders are on the top of the boom. This protects them from collision and concrete spills.



The hydraulic hose box can be lowered without outriggers down and putting the hoses within easy reach of the operator.



2 slewing cylinders on each side of the turret guarantee safe and dependable operation.



Additional storage boxes for hoses and pipes can be loaded and unloaded by fork lift, crane or the pumps own boom to place them where they are needed.



The hose boxes can be customized. The plastic sleeves are angled to allow residual concrete to run off.



## TECHNISCHE DATEN

Pump battery		P 2020	P 2023-110/75	P 2023-110/75
Hydraulic drive	l/min	320	380	450
Performance	<i>K = piston sided, S = rod sided</i>	K	S	
Max. theor. output	m <sup>3</sup> /h	51	90	114
Max. number of strokes	min.	14	24	23
Max. concrete pressure	bar	126	70	85

*Performance data is max. theoretical (Max. output and max. pressure cannot be achieved simultaneously.)*

Placing boom		28 ZR
Delivery line diameter		DN 125
Length of end hose	m	4,0
Vertical reach	m	27,71
Horizontal reach	m	23,67
Number of articulations		4
Height of articulations	m	4,05 / 11,13 / 16,66 / 22,18
Slewing range		370°
Outrigger load, front	kN	130
Outrigger load, rear	kN	100

## WORKING RANGE

### S 28 X

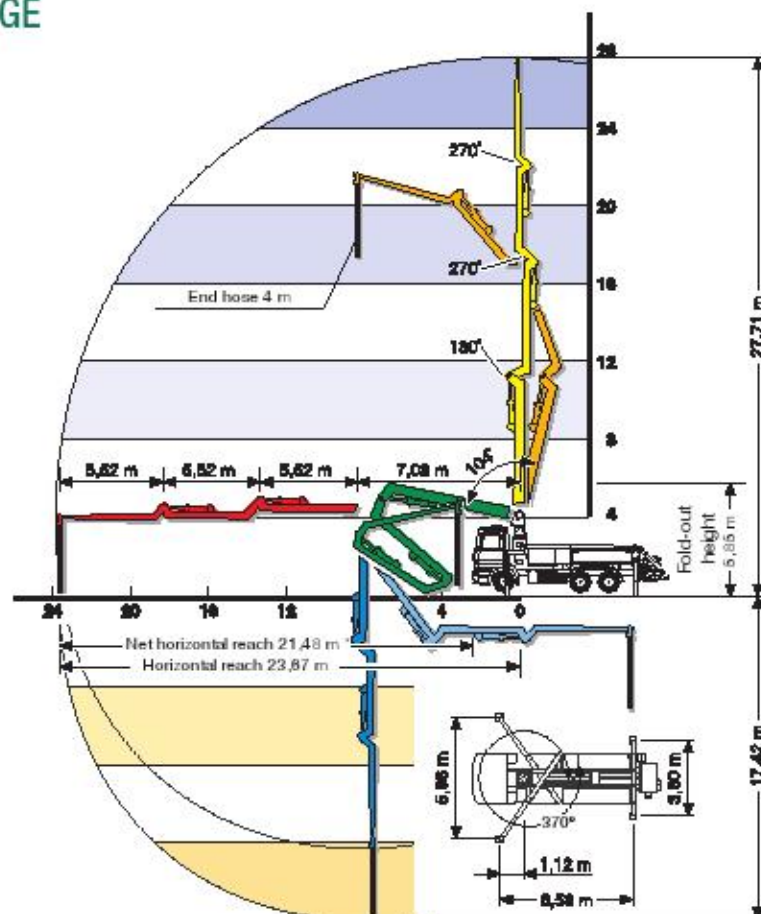

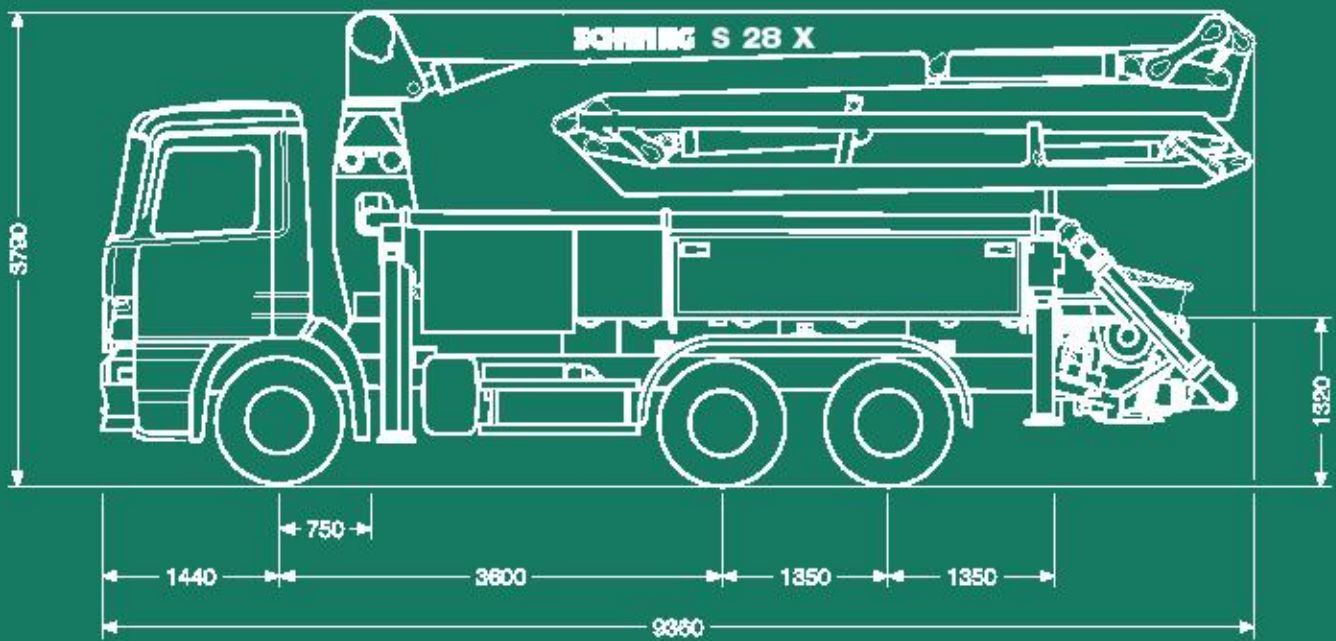

## SCHWING-STETTER MOVES CONCRETE. **WORLDWIDE.**

Wherever concrete is produced and moved is where you will find Schwing-Stetter machinery.

With plants in Germany, Austria, USA, Brazil, Russia, China and India as well as with more than 100 sales and service facilities, the group of companies is always close to the customer.

Our wide range of products with something for every application is what makes Schwing-Stetter the No. 1 system supplier for concrete machinery worldwide.



SCHWING GMBH  
 P.O. Box 20 03 62 . D-44647 Herne / Germany  
 Phone (0) 23 25 / 9 87-0 . Fax (0) 23 25 / 7 29 22  
[www.schwing.de](http://www.schwing.de) . [info@schwing.de](mailto:info@schwing.de)

Subject to modifications in the  
 interest of technical progress.  
 The exact standard scope of