

# CONCRETE RECYCLING PLANT

RA 6 | RA 12 | RA 20



## SCHWING-STETTER MOVES CONCRETE. **WORLDWIDE.**

Wherever concrete is produced and moved is where you will find Schwing-Stetter machinery.

With plants in Germany, Austria, USA, Brazil, Russia, China and India as well as with more than 100 sales and service facilities, the group of companies is always close to the customer.

Our wide range of products with something for every application is what makes Schwing-Stetter the No. 1 system supplier for concrete machinery worldwide.



CONCRETE MIXING PLANTS



TRUCK MIXER



TRUCK-MOUNTED CONCRETE PUMPS



STATIONARY CONCRETE PUMPS



SEPARATE PLACING BOOMS



CONCRETE RECYCLING PLANTS

## STETTER CONCRETE RECYCLING PLANT.

### ECOLOGICAL OBLIGATION – ECONOMICAL SOLUTION.

Concern for our environment, guidelines from legal authorities and above all, an increased awareness of costs are the main reasons for worldwide efforts to solve the concrete industry's disposal and recycling problems.

Profiting from extensive experience gained with sieve/cyclone separation systems, Stetter had already developed and implemented the concrete recycling plant by 1976.

Since then, our systems have proved to be unusually reliable, economical and highly wear-resistant. Our permanent development efforts have made the Stetter concrete recycling plant an exceptionally strong product. We now offer three different sizes – from 6 to a maximum of 20 m<sup>3</sup>/h concrete recycling.

#### THE BENEFITS OF OUR CONCRETE RECYCLING PLANT:

- Easy to operate
- Low personnel costs thanks to automatic operation
- Short vehicle downtimes during cleaning
- No disposal costs
- Recycled aggregates
- A construction that is quiet and exceptionally resistant to wear
- Variable installation possibilities
- Low operating costs



*Standard design RA 20.*

## FUNCTION AND WASHING PROCESS.

Easy and effective.



### PREPARATION, STEP BY STEP

Using an ultrasonic sensor, the system switches on automatically when a truck arrives.

The surplus concrete is fed into the washing drum with the help of vibrators in the hopper. Depending on the system, up to three trucks can be unloaded simultaneously.

At the touch of a button, the water booms supply the cleaning water for the mixing truck.

The concrete is cleaned in the washing drum using the reverse flow principle.



Mixed gravel with a grain size greater than 0.2 mm is extracted from the washing drum via the vibrating chute. A sieve insert is used for additional drainage of the mixed gravel. A thermostat-controlled heater is also available for the vibrating chute.

The waste water contains concrete particles with a grain size smaller than 0.2 mm.

An agitator is used to keep the waste water in motion. This prevents fine particles from settling and enables the water to be used again for producing new concrete.



If a concrete mixer is not available, the recycling plant can also be operated without agitator basins. In this case, a sedimentation tank system guarantees optimum function.

### THE WASHING PROCEDURE ACCORDING TO THE REVERSE FLOW PRINCIPLE

The washing drum principle used by Stetter provides you with numerous benefits:

- The design concept (spirals connected directly to the drum) guarantees the least possible wear
- Quick intake of solids (e.g. partial quantity, 2 m<sup>3</sup> in 2 minutes or by larger quantities, 1 m<sup>3</sup> in 3 minutes for the RA 20)
- Separation of the surplus materials into mixed gravel from 0.2 to 63 mm and waste water, containing cement, fine sand and washable elements up to 0.2 mm
- Low replacement part costs
- Low-noise operation
- Water conservation due to closed water circulation during washing operation
- Protection against overflow and automatic drum-feed cutoff

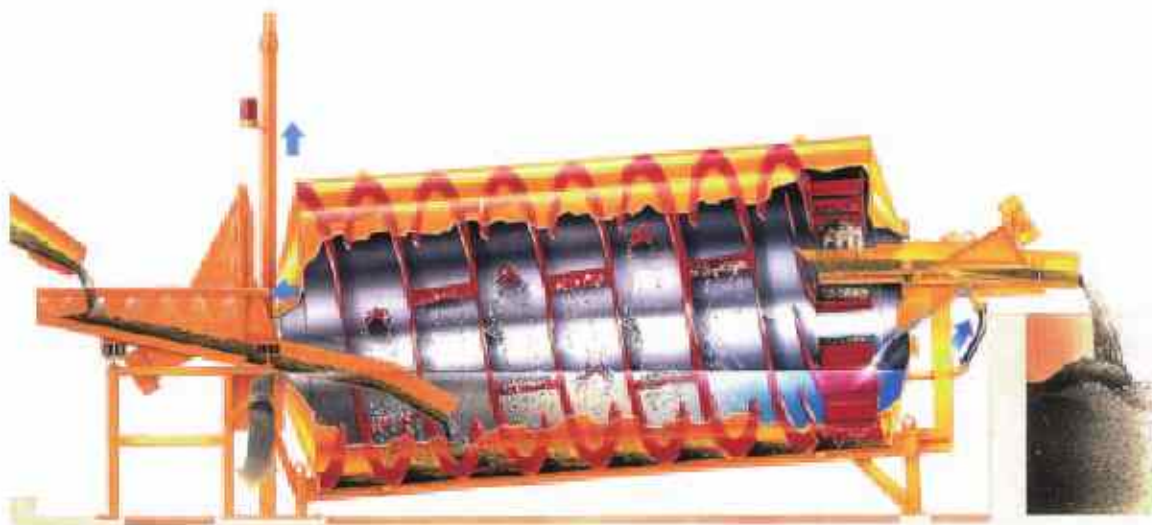

The washing process in the drum works according to the reverse flow principle. Solids from 0.2 mm to 63 mm are transported against the flow of water using continuous spirals. Materials from 0.2 to 63 mm are extracted using a scoop on the vibrating chute, while the finer particles up to 0.2 mm are transported with the water through the drum overflow. Flushing water for the washing drum can be drawn directly from the mains using an electromagnetic valve, or can be pumped from the storage basin using a submersible pump. The overflow warning for the washing drum is released by measuring the power consumption of the drive motors and automatic switch on/off control of the feed hopper vibrators.

This safety feature is possible with the free feed system used in the Stetter washing drum.

During the cold season intermittent operation prevents water from freezing in the drum. For longer winter breaks, the water can be drained using a special plug.

## RA 12/20

**Versatility and performance.**

The RA 20 is the optimum, environmentally sound and economical solution for surplus concrete quantities of up to 20 m<sup>3</sup>/h.



*The RA 20 with square feed hopper, width 3.2 m, two water booms and optional hopper.*



*RA 12 overview: In addition to the agitator basins, sediment and surface water basins can be installed as an option.*

*The customers can also integrate and use their own basins.*

## RA 6

Stationary or mobile.

The RA 6 is the answer for smaller quantities of surplus concrete. In the stationary design, they are assembled similar to the RA 12/20.

In the mobile version, washing drums and semicircular feed hoppers are mounted to a joint transport frame. Therefore, all that is needed is a compacted levelled ground. Transport and assembly is made much easier. The slurry water is temporarily stored in an agitator container.

Both variants feature:

- Compact design
- Semicircular feed hoppers with 1.9 m width
- Discharge height up to 2 m with optional extension



OPTIONAL EQUIPMENT



*Alternatively, a semicircular feed hopper with a 2.5 m width is available for the RA 12/20.*



*Aboveground design with double container for the temporary storage of waste water, recommended for rocky foundations or mobile use.*



*Design with conveyor belt for extracting solids.*



*Inground design with ground-level feed height.*



*Hydraulic skip for feeding surplus materials from concrete pumps; 1,100 liter capacity.*





**RA 12/20 STANDARD**

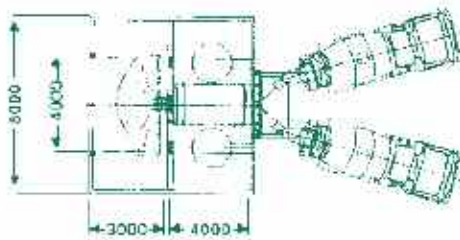
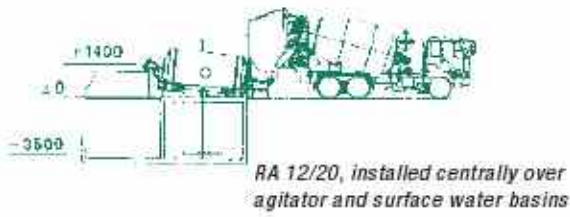

**RA 12/20 WITH FEEDER SKIP**

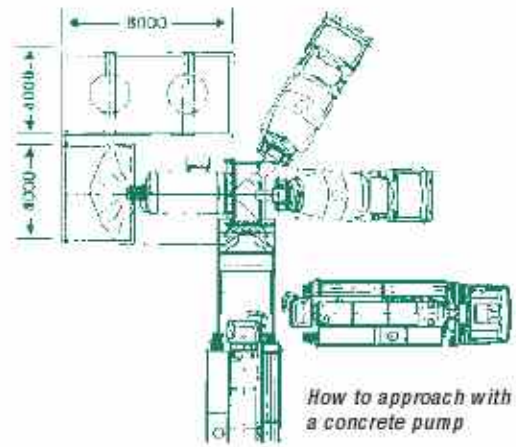
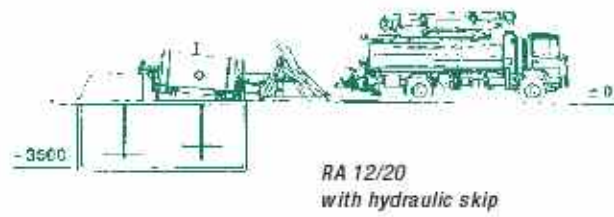

**RA 12/20 INGROUND**

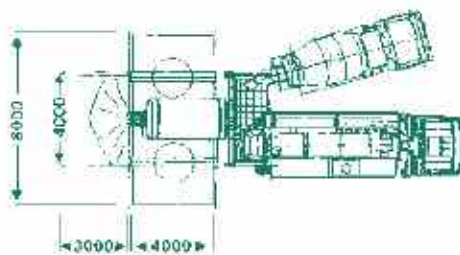
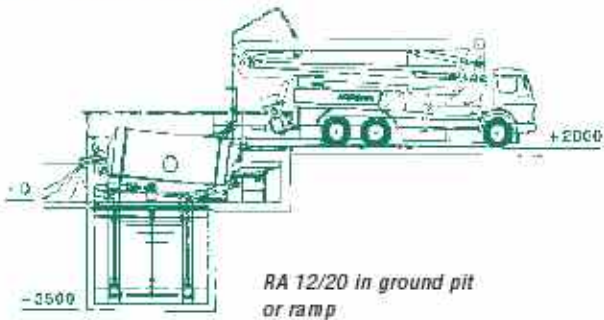

**RA 12/20 WITH DRAINAGE GRID**

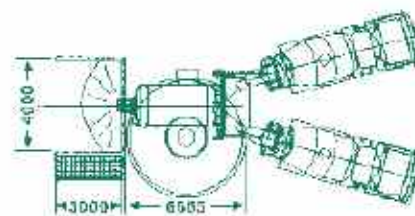
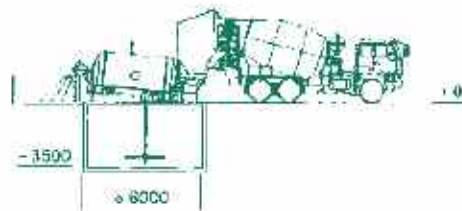

## SUMMARY.

### Project planning and technical data.

Stetter plans the concrete recycling plant according to your specific local requirements and wishes. We guarantee the highest degree of transparency from the planning phase to assembly and commissioning.

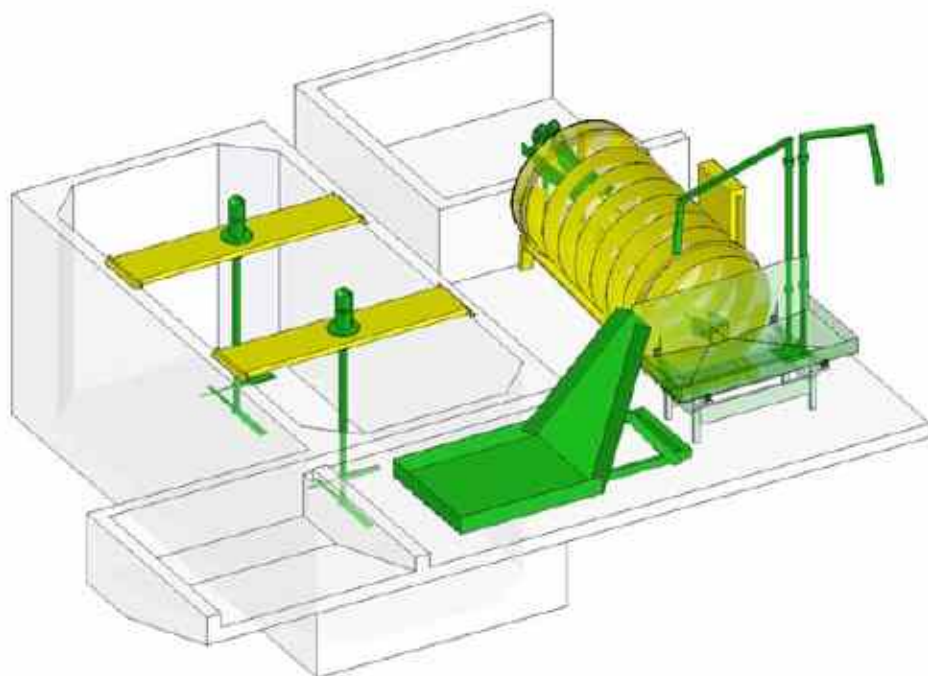

*3D CAD representation of an RA 20 with agitator and sedimentation basin.*

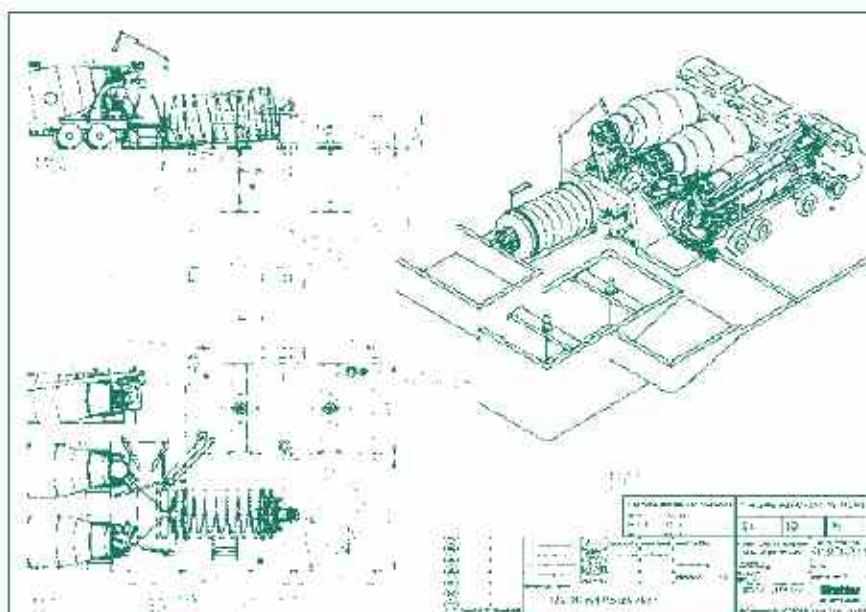

*Project drawing*

## TECHNICAL DATA

SYSTEM TYPE:		RA 6	RA 12	RA 20
Washing capacity for normal concrete	m <sup>3</sup> /h	6	12	20
Washing capacity for normal mortar	m <sup>3</sup> /h	–	5	8
Feeding of solids, partial quantity with drum empty, max. particle size 63 mm	m <sup>3</sup>	0.5/1 min	1/1 min	2/2 min
Feeding of normal concrete, continuous	m <sup>3</sup> /min	0.1	0.2	0.33
Screen cut	mm	0.2	0.2	0.2
Flushing water quantity (adjustable)	m <sup>3</sup> /h	6–10	7–12	8–15
Rinsing water connection for washing drum	DN	50	50	50
Flushing water connection for water booms	DN	80	80	80
Slurry water drain line	DN	200	250	250
Water capacity in drum	m <sup>3</sup>	0.9	2	4
Run-on time washing drum (adjustable)	min	15	20	20
Max. number of vehicles for approaching simultaneously	–	1	2–3	3

## FEED HOPPER – DIMENSIONS:

Circular	m	1.8 x 1.4	2.5 x 1.3	2.5 x 1.3
Rectangular	m	–	3,2 x 1,4	3,2 x 1.4
Feed hopper height	m	1.4	1.53	1.53
Total dimensions of base system	m	5 x 3.1 x 2.4	5.7 x 3.2 x 2.7	7.3 x 3.2 x 2.8
Motor rating washing drum	kW	1 x 3	2 x 2.2	2 x 3
Connected load of base system approx.	kVA	10.5	14.5	17
Transport weight of drum + feed hopper approx.	t	2.3	3.8	5
Hydraulic skip, optional	–	Yes	Yes	Yes

## AGITATOR BASINS:

Drive power per agitator	kW	4–5.5
Dimensions of agitator basin	m	Depending on operational requirements
Agitating interval approx.	min	3 min runtime, 15 min pause, adjustable
Slurry water pump	kW	3.7–9
Throughput at 2 bar and 1.5 bar	m <sup>3</sup> /h	35–60

SCHWING-STETTER ALWAYS CLOSE TO THE CUSTOMER.



- ▣ Parent plant
- Production subsidiary
- Own/independent sales and service company

Subject to technical and dimensional modifications.  
Photos are not binding.  
The exact scope of the delivery is listed in the offer.



Stetter GmbH | Postfach 19 42 | 87689 Memmingen, Germany | Phone +49 (0) 8331 / 78-0  
Fax +49 (0) 8331 / 78-275 | info@stetter.de | www.stetter.de